

# Utility Management Consulting

## Specialist Studies

### Reliability Studies



Utility investment and strategic plant decisions that affect service reliability should be explicitly evaluated on the basis of their cost and benefit implications. The main objective for system planners should thus be that the marginal cost of changing system reliability or planning the system to a specified reliability level should correspond to the resulting change in the value of the improved service to the end-user. To effectively achieve this objective a suite of techniques and technologies are provided.

In their simplest form these techniques can be defined as:

- Composite System Reliability Assessment
- Parametric Studies
- Substation Reliability Assessment
- Distribution System Reliability Assessment, and
- Value-Based Planning Methodology

#### Composite System Reliability:

Single or Multiple Load Level Transmission and Sub-Transmission System Adequacy Assessment are performed through a Contingency Enumeration process. Both AC and DC Loadflow Analysis are possible.

#### System Adequacy Indices are quantified through:

- Deterministic Contingency Analysis
- Load curtailment, voltage violations, overload violations
- Voltage Collapse, network cascading, network islanding
- Probabilistic assessment of system violations
- Frequency, duration and severity of events
- Probabilistic Load Curtailment Assessment
- Expected unserved energy (EUE) and customer impact
- Calculation of customer damages due to unreliability

#### Analysis includes optimal corrective actions:

Interactively provide corrective actions during contingency enumeration – adjusting generator real powers, phase shifter angle and load shedding to eliminate branch overloads, interface limit violations, and bus voltage limit violations.

#### Analysis is refined through parametric studies:

Involves a series of power flows that monitor the changes in one set of power flow variables with respect to another in a systematic fashion. (e.g. Voltage Collapse)

#### Base Software:

All techniques are supported by PTI –TPLAN software.

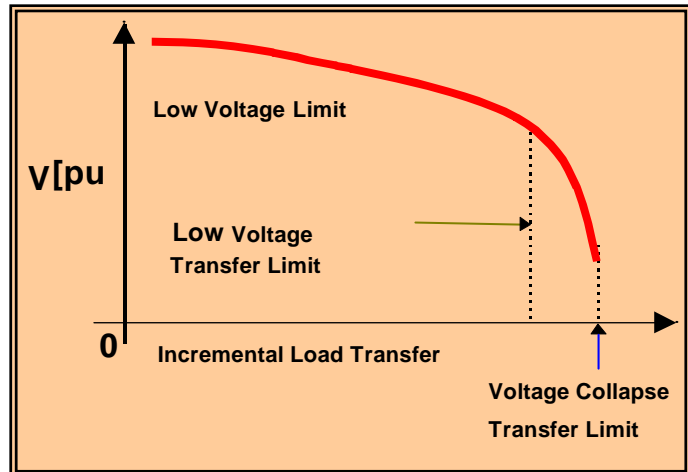

#### Distribution Reliability:

Approximately 80% of all interruptions experienced by customers are due to faults on the Distribution system. One of the most challenging aspects of Distribution System planning is the optimization of the system in terms of outage performance or reliability. This is achieved through the application of a number of analytical techniques and methods.

These Analytical methods include:

- Calculate Historical Failure Rates
- Model Chosen Feeders
- Calibrate Model with Physical Inspection Data
- Determine Baseline Reliability Performance
- Assess Reliability Goals and Targets
- Identify Applicable Mitigation Strategies
- Conduct Parametric Studies Using Predictive Model (PTI PSS/ADEPT – DRA) through Monte Carlo Simulation
- Select Viable Mitigation Strategies

#### Distribution Performance Indices include:

SAIDI, SAIFI, CAIDI, CAFI, ASAI, CTAIDI, ASIFI, ASIDI and MAIFI.

## Substation Reliability Assessment:

The reliability of a substation can be measured by the frequency and duration of station related outage events. These outages include:

Failure of the sub-system supplying the station, faults on the substation equipment, failure of a breaker to clear a fault or the false tripping of a breaker, operational failures as well as scheduled and unscheduled maintenance.

### Substation Reliability Assessment provides for:

- Comparing substation configuration alternatives
- Evaluate the sensitivity of substation performance to various system conditions such as: Equipment outage statistics, Equipment rating and Load level.
- Determining the impact of equipment maintenance on reliability, and
- Comparison of substation configuration and breaker arrangement.

### Substation Reliability Indices provides for:

Maintenance and Non-maintenance events for both post-fault and post switching conditions.

### Software:

Substation reliability assessment is supported by PTI TPLAN-SRA software.

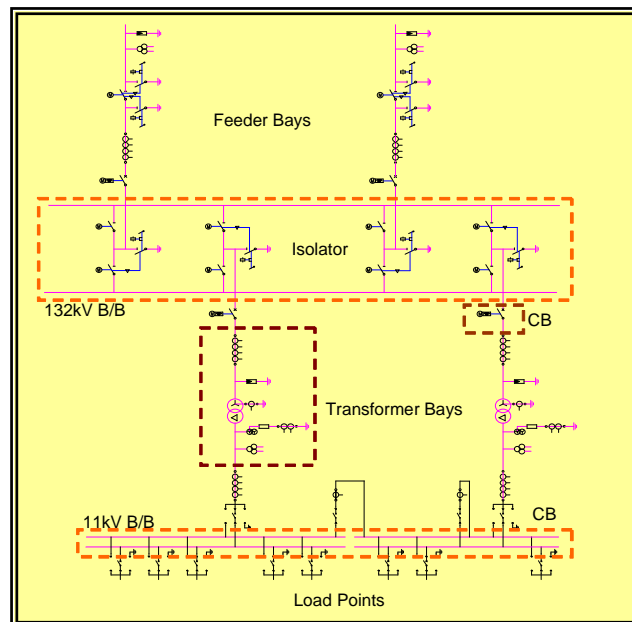

## Value Based Planning:

The above technologies can individually be utilized to solve a variety of probabilistic transmission, distribution, station and plant related problems. Through the integration of the technologies with system planning techniques, a higher level, value-based approach of alternative evaluation is achieved.

The value-based approach provides the basis for answering the fundamental economic questions in reliability planning: How much reliability is adequate. This can be answered through the utilization of these technologies within three basic steps:

- The identification of alternative network options,
- Comparing alternative options within a value-based framework, and
- The proposal of a solution that complies with the value-based criteria.

It is important to note that the probabilistic techniques does not eliminate experience or judgment, but enhance the quality of decision-making.

## Customer Damage:

Establishing the worth of a specific level of reliability involves quantifying customer perspective with regard to interruption or outage cost.

Approaches that are followed to assess the cost of interruptions vary between analytical methods, case studies and customer surveys. The most widely accepted being the customer survey.

Commonly used queries to obtain information regarding cost of interruptions includes:

- Direct estimation of losses resulting from a given interruption scenario, and
- Questions based on the Willingness to Pay (WTP) and Willingness to Accept (WTA).

